

SELF-PROPELLED SCISSOR LIFT

GTJZ SERIES

PARAMETER TABLE

Model (Hydraulic motor drive)	GTJZ06	GTJZ08	GTJZ10	GTJZ12	GTJZ14
Max. Working Height (m) A	7.8	10.1	12.2	13.95	15.75
Max. Platform Height (m) H	5.8	8.1	10.2	11.95	13.75
Overall Length (m) L	1.82	2.48	2.48	2.48	2.83
Overall Width (m) B	0.76	1.15	1.15	1.15	1.25
Overall Height(Rails up)(m)	2.22	2.32	2.45	2.57	2.61
Overall Height(Rails down)(m) C	1.87	1.83	1.95	2.06	2.1
Platform Size(L×W) (m) E×F	1.66×0.74	2.32×1.13	2.32×1.13	2.32×1.13	2.93×1.51
Platform Extension Size(m) D	0.9	0.9	0.9	0.9	0.9
Ground Clearance(Stowed)(mm)	100	100	100	100	100
Ground Clearance(Raised)(mm)	20	20	20	20	20
Wheel Base (m)	1360	1900	1900	1900	1900
Load capacity (kg)	230	230	320	320	230
Load capacity On Extension (kg)	110	110	110	110	110
Turning Radius(m)	1.7	2.2	2.2	2.2	2.6
Travel Speed(Stowed)(km/h)	3.2	3.2	3.2	3.2	3.2
Travel Speed(Raised)(km/h)	0.8	0.8	0.8	0.8	0.8
Up/Down Speed(m/s)	0.18/0.25	0.18/0.25	0.18/0.25	0.18/0.25	0.18/0.25
Gradeability	25%	25%	25%	25%	20%
Maximum Working Slope (°)	2°/3°	2°/3°	2°/3°	2°/3°	2°/3°
Tyre(mm)	φ305×114	φ381×127	φ381×127	φ381×127	φ381×127
System pressure (Mpa)	24	24	24	24	24
Lifting Motor (V/kW)	24/3	24/4.5	24/4.5	24/4.5	24/4.5
Batteries (V/Ah)	4×6/225	4×6/225	4×6/240	4×12/300	4×12/300
Charger(V/A)	24/30	24/30	24/30	24/30	24/30
Weight (kg)	1500	2650	2850	3050	3450

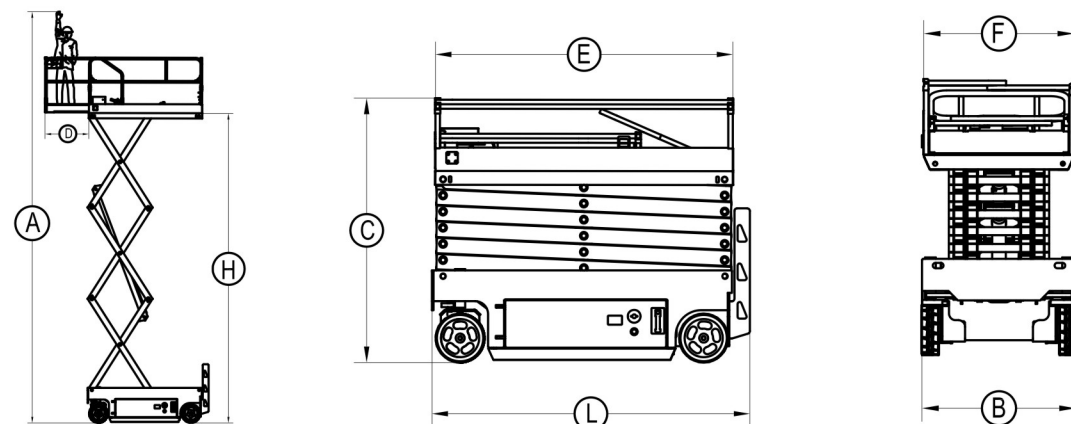

STANDARD CONFIGURATION

- ◆ 2-Wheel Hydraulic Motor Drive
- ◆ 2-Wheel Steering
- ◆ High/Low travel speed
- ◆ Extension Platform
- ◆ Foldable Guardrails
- ◆ Tilt sensing Alarm
- ◆ Down Alarm
- ◆ Safety Support
- ◆ Timer
- ◆ Intelligent Charger
- ◆ Swing-out Tray
- ◆ Pothole Protection Device
- ◆ Emergency Down Device
- ◆ Emergency Release Brake
- ◆ Anti-collision Protection of Platform