

### SPECIFICATIONS

Size	Metric	British
Max. Working Height <b>A</b>	5.6m	18ft 5in
Max. Platform Height <b>B</b>	3.6m	11ft 10in
Overall Length <b>C</b>	1.44m	4ft 9in
Overall Width <b>D</b>	0.76m	2ft 6in
Overall Height(Rails Up) <b>E</b>	1.99m	6ft 6in
Overall Height(Rails Down) <b>F</b>	1.62m	5ft 4in
Platform Size(Length×Width)	1.29m×0.70m	4ft 3in×2ft 4in
Platform Extension Size <b>G</b>	0.60m	2ft
Ground Clearance(Stowed/Raised)	0.06m/0.015m	2in/1in
Wheelbase <b>H</b>	1.05m	3ft 5in
Turning Radius(Inside/Outside)	0.40m/1.55m	1ft 4in/5ft 1in
Tyres	φ230×80mm	φ230×80mm

Performance		
S.W.L	240kg	529lb
S.W.L On Extension	100kg	220lb
Max. Occupants	2	2
Gradeability	25%	25%
Travel Speed(Stowed)	4.0km/h	4.0km/h
Travel Speed(Raised)	0.5km/h	0.5km/h
Max. Working Slope	1.5°/3°	1.5°/3°
Up/Down Speed	27/20sec	27/20sec

Weight		
Overall Weight	920kg	2028lb

Power		
Hydraulic Tank	3L	3L
Battery	2×12V/85Ah	2×12V/85Ah
Charger	24V/15A	24V/15A
Driving Motor	2×24VDC/0.4kW	2×24VDC/0.4kW
Lifting Motor	24VDC/1.2kW	24VDC/1.2kW

\* The platform height plus 2m (7ft in British standard) is the working height.  
Standards Compliance

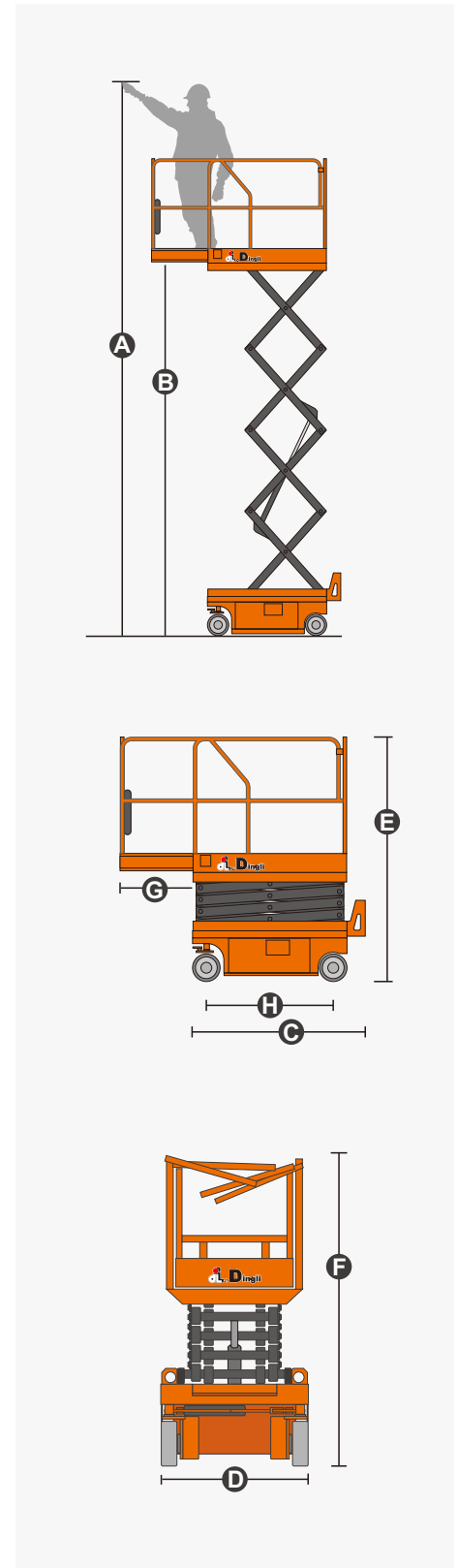

## FEATURES

### Standard Items

- Proportional Joystick Controls
- Self-Locking Gates
- One-Way Platform Extension Deck
- Drivable At Full Height
- Non-Marking Tires
- 4×2 Drive
- Four-Wheel Braking
- Emergency Descent System
- Tubing Explosion-Proof System
- Onboard Fault Diagnostic System
- Tilt Alarm
- Motion Alarm
- Horn
- Hour Meter
- Safety Arm For Troubleshooting
- Standard Transport Forklift Holes
- Charging Protection System
- Flashing LED Beacon
- Foldable Guard Rails
- Automatic Pothole Protection
- Drive Enable
- Automatic One-Way Platform Extension Deck
- Manual Brake Release
- Lanyard Attachment Point
- Tie-Down And Lifting Points
- Platform Load Sense System

### Optional Items

- **Factory Hydraulic Oil**
- No. 46 Hydraulic Oil (Mineral Oil)\*\*

### Additional Items

- GPS Unit
- Biodegradable Hydraulic Oil
- AC Power Cord to Platform
- Air Line to Platform
- Work Light Package
- Footpedal Switch
- Anti-Collision Bar on Platform

\*\* Factory Default, If You Have Other Needs, Please Inform Dingli Regional Sales.

## ZHEJIANG DINGLI MACHINERY CO., LTD.

No. 188 Qihang Road, Deqing, Zhejiang P.R.China 313219

Telephone +86(572)8681688

Fax +86(572)8681960

E-Mail [export@cndingli.com](mailto:export@cndingli.com)

[Http://www.cndingli.com](http://www.cndingli.com)

